

# Operation of the SRI TOGA GC configuration

The SRI TOGA GC configuration is assembled on the 8610C GC chassis. Typically the GC is equipped with TCD and HID detectors, but other detectors such as FID may be ordered as well depending on the customer's needs.



Two 2 meter long packed columns are installed in the GC's column oven, a Silica Gel column and a Molecular Sieve 13X column. The two columns separate the transformer gases in the same way that SRI's Multiple Gas#1 GC configuration does. To understand how the two columns work to perform the separation it would be useful to review the Multiple Gas#1 GC instructions (download from [www.srigc.com](http://www.srigc.com)).

The hardware which allows the TOGA GC to extract the gases from the transformer oil (or other liquid) is mounted on the left side of the GC and inside the GC's valve oven. The special parts are the Permeation Loop (which extracts the gases), two solenoid valves (which purge the loop with helium), two peristaltic pumps (which are controlled by the PeakSimple Data System) and a Standard Preparation Module.

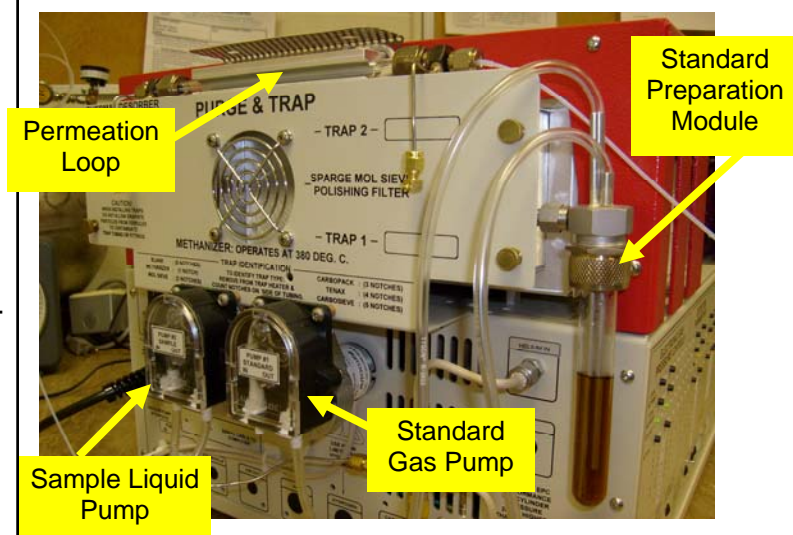
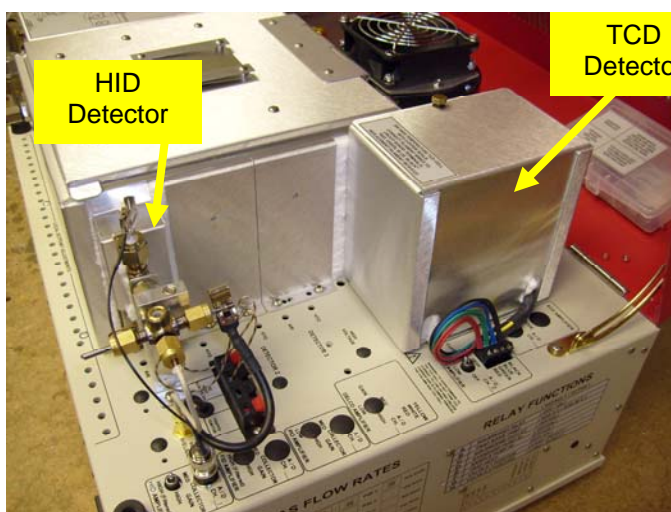
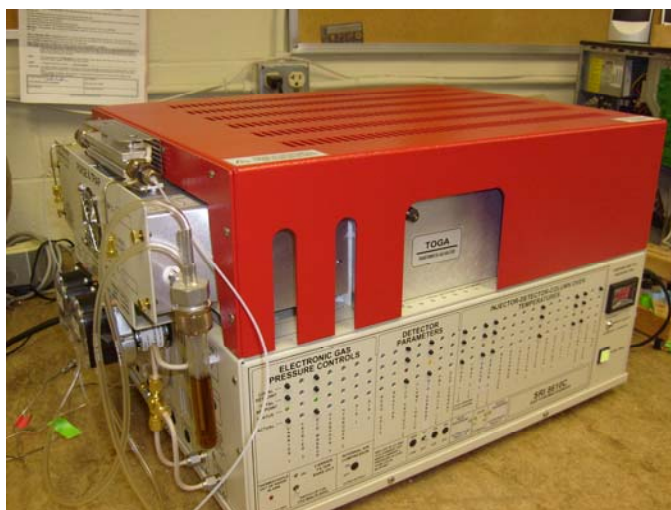

# Operation of the SRI TOGA GC configuration

A second gas sampling valve is located in the GC's valve oven. This second valve is not required for the Multiple Gas#1 GC configuration, but otherwise the TOGA and Multiple Gas #1 GC configurations are the same.

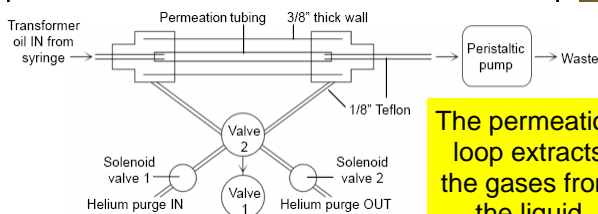
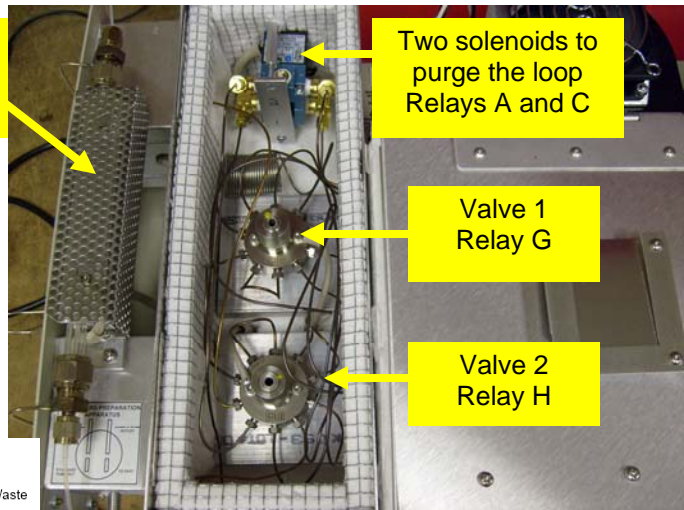

The permeation loop extracts the gases from the liquid

The permeation loop consists of a glass tube with a silicone tube suspended in the middle. The liquid is pumped through the silicone tubing. The volume between the silicone and the glass is what is injected onto the columns when valves 1 and 2 are rotated. Solenoid valves 1 and 2 purge this volume ( the loop volume ) with helium carrier gas prior to the extraction sequence.

Notice that Valve 1 reverses the order of the two columns. The upstream column becomes the downstream column, but neither column is back-flushed. The flow direction of the carrier gas does not change.

Valve 2 places the permeation loop volume in series with the two columns ( in the Inject position ) and isolates the permeation loop in the Load position.

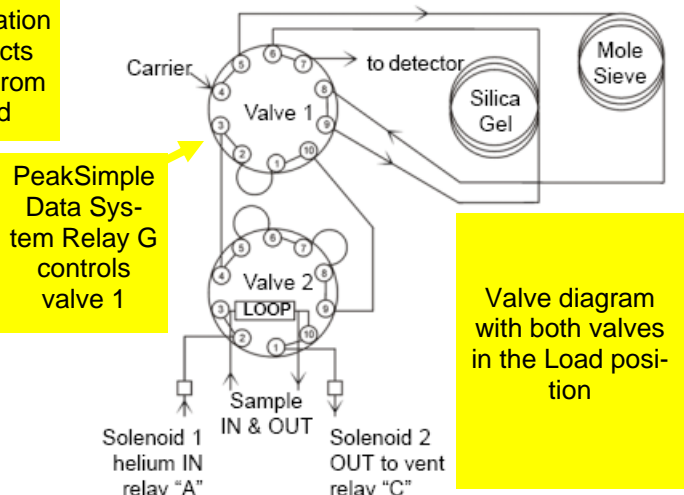

Valve diagram with both valves in the Load position

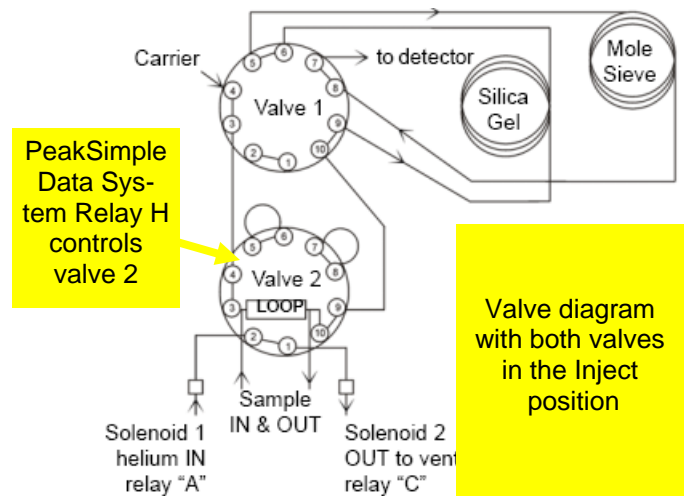

Valve diagram with both valves in the Inject position

# Operation of the SRI TOGA GC configuration

Enter the event table sequence shown at right. Please understand that the times shown are approximate times. Due to differences from column to column and variations in liquid samples, you may want to make modifications to the times shown after operating the system.

At time 0.00 the detector signal is auto-zeroed and a sound is made on the computer's speaker.

At time .1, Relay C turns on which vents the permeation loop.

At time .2, Relay A turns on which purges the loop with helium carrier gas.

At time 1.00, Relay A turns off now that the loop has purged for about 45 seconds.

At time 1.5, Relay C turns off after venting the helium pressure in the loop for 30 seconds. This is important because if the loop were still pressurized with helium the silicone tubing would be squeezed shut and no liquid could be pumped through it.

At time 1.6, relay E turns on the liquid peristaltic pump. The liquid passing through the silicone tubing ( 2ml/minute ) permeates any gases in the liquid into the space surrounding the silicone ( which is initially pure helium ) as it tries to reach an equilibrium. Helium in the surrounding loop volume permeates in the other direction through the silicone tubing and is carried away by the flowing liquid. Eventually equilibrium is reached where the concentration of the gases in the liquid is equal to the concentration of the gases in the surrounding loop volume.

At time 9.9, Relay E turns off stopping the flow of liquid. This time may be modified to provide a longer equilibration time, or reduced to speed up the analysis. If the time is reduced, fewer gas molecules may permeate thus reducing the size of the peaks on the final chromatogram.

Channel 1 events	
Toga.evt	
Time	Event
0.000	ZERO
0.000	SOUND
0.100	C ON (Solenoid 2 Purge Vent)
0.200	A ON (Solenoid 1 Helium Purge)
1.000	A OFF (Solenoid 1 Helium Purge)
1.500	C OFF (Solenoid 2 Purge Vent)
1.600	E ON (Liquid Peristaltic Pump)
9.900	E OFF (Liquid Peristaltic Pump)
10.000	G ON (Valve1)
10.000	H ON (Valve2)
10.300	H OFF (Valve2)
10.400	C ON (Solenoid 2 Purge Vent)
10.900	C OFF (Solenoid 2 Purge Vent)
16.000	G OFF (Valve1)

Loop is flushed with helium prior to extraction of gases

Liquid is pumped through silicone

Valves are rotated to inject loop contents and sequence columns

Add... Change... Remove Describe...  
Load... Save... Clear Print  
OK Shift...

At time 10.00, both Relays G and H are turned on, rotating Valves 1 and 2 to the INJECT position. This not only injects the loop contents, but also switches the order of the Silica Gel and Molecular Sieve 13X columns so that the Mole Sieve column is downstream.

At time 10.3, Relay H is turned off which rotates Valve 2 back to the LOAD position. If this is not done, the carrier gas continues to strip gas molecules from the silicone tubing, depositing them onto the columns. This makes an ugly elevated baseline disturbance on the chromatogram.

At time 10.4, Relay C is turned on venting the loop. The loop would be under pressure at this point since it was just in series with the columns. If the pressure is not vented the silicone tubing will be pinched shut and not allow liquid to flow.

At time 10.9, Relay C is turned off, having vented the pressure in the loop for 30 seconds.

At time 16.00, Relay G is turned off, rotating Valve 1 back to the LOAD position. The exact time for this event will vary depending on the elution time of Ethane. **See the discussion of Valve timing in the Multiple Gas#1 instructions.**



# Operation of the SRI TOGA GC configuration

Click on Edit/Channels in PeakSimple and enter a temperature program in Channel 1.

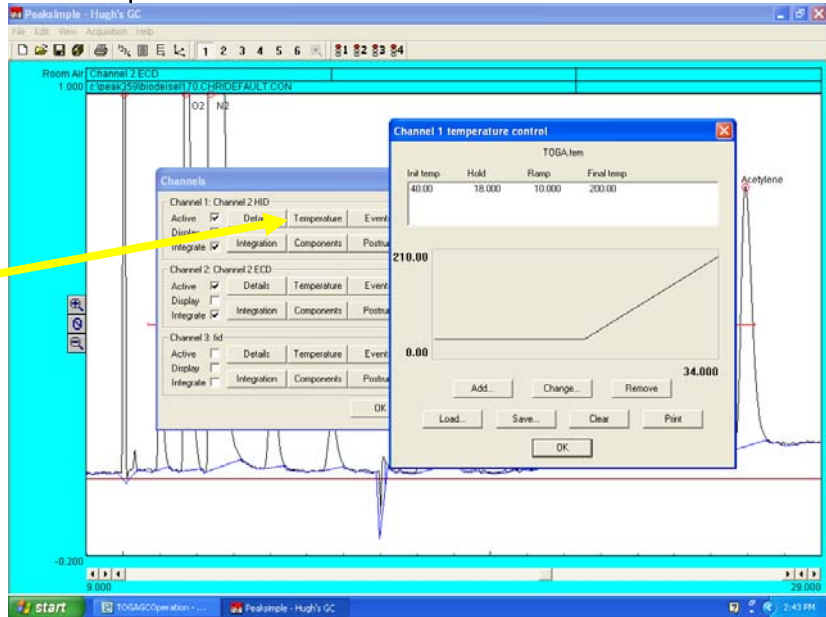

The temperature program should be approximately like the one shown. The initial temperature of 40 degrees should be held constant until the CO peak has eluted and Relay G actuated to return Valve 1 to the LOAD position. The exact timing of this will vary from GC to GC as it depends on the carrier gas flow rate and particular column set installed. See the Multiple Gas #1 instructions for more details on determining the exact timing.

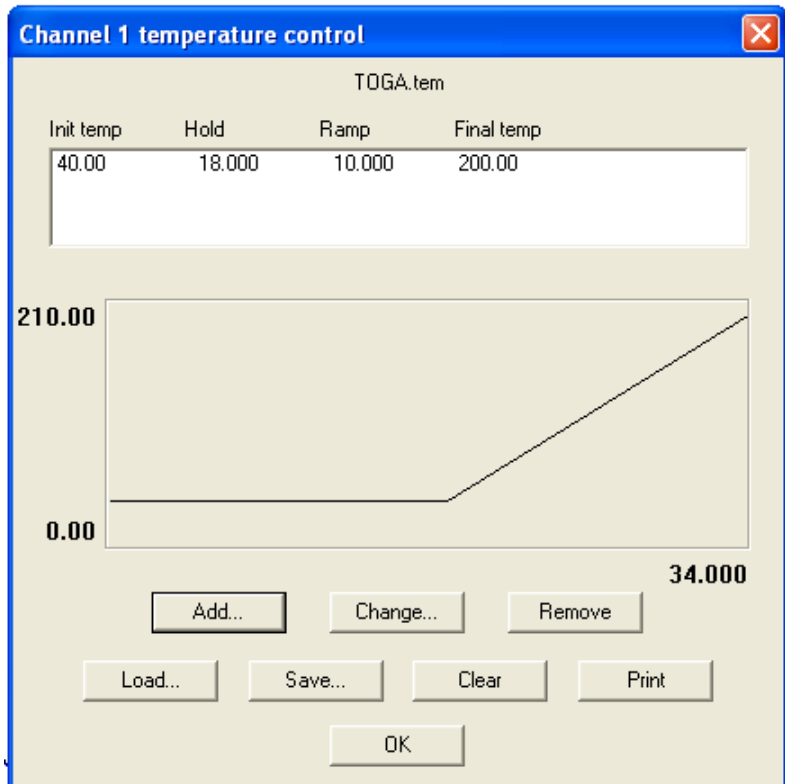

# Operation of the SRI TOGA GC configuration

Connect your liquid sample to the 1/16" Teflon inlet tubing. Transformer oil is often transported to the lab in a 50ml glass syringe like the one shown in the photo.

Connect the downstream side of the sample peristaltic pump to a waste beaker.

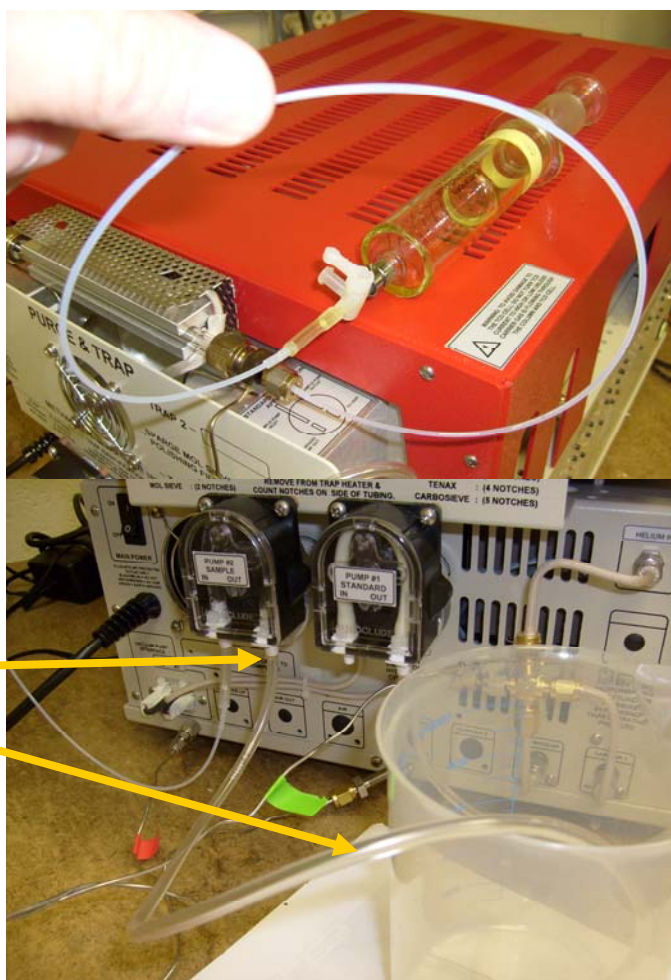

Start the analysis. Peaks will appear as shown if the Event table and temperature program timing is correct, and if the gases are actually present in the liquid sample.

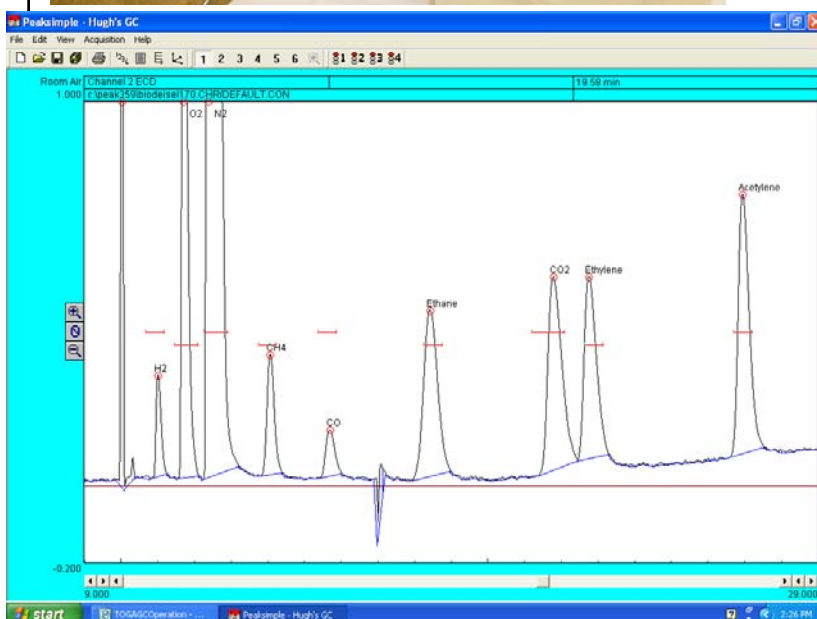

# Operation of the SRI TOGA GC configuration

Some transformer oils may weep slightly through the silicone tubing. Look inside the permeation loop periodically to inspect for oil seepage. This will look like an oily deposit on the glass.

The oil seepage can be flushed out by removing the swagelok cap from the two flushports.

Use a syringe to flush solvent through the permeation loop to remove the oily deposits. Blow dry with air or carrier gas and reconnect the caps.

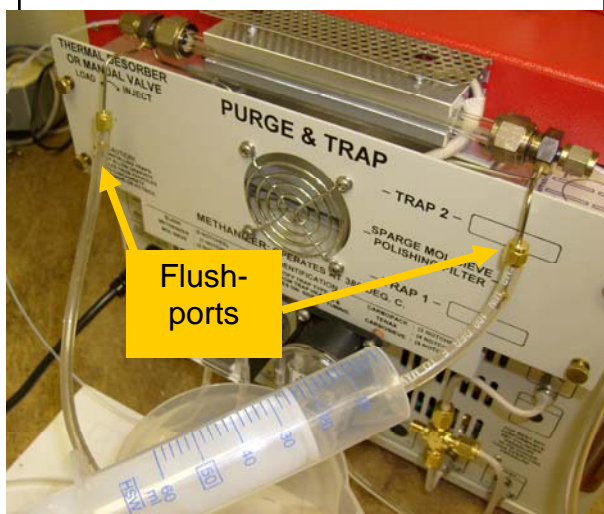
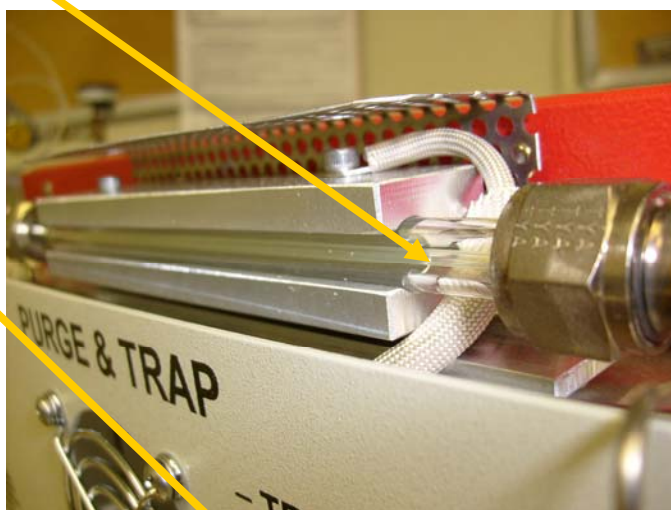



# Operation of the SRI TOGA GC configuration

The TOGA GC configuration includes a standard preparation module which consists of a peristaltic pump ( controlled by Relay D ) which pumps a calibration gas ( at 2ml/minute ) into a test tube ( 16mm test tube ).

As the calibration gas bubbles through the liquid in the test tube, the gases are dissolved into the liquid until equilibration occurs. This may take several hours.

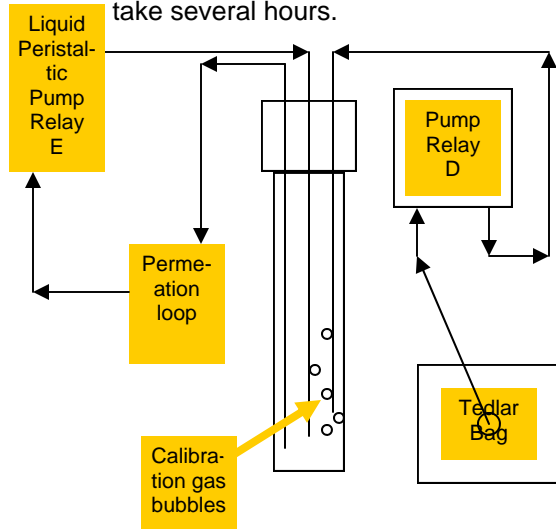

Because the gas is bubbling continuously once the liquid is equilibrated with the calibration gas the concentration of the gas in the liquid does not change further. The liquid can then be used to calibrate the TOGA GC.

For water the solubility of gases is listed in the following table. For transformer oils the solubility will be different depending on the composition of the oil.

Gas	Grams of gas dissolved per 100ml 100% gas at 1 atm.	ppm Wtgas/1gmH2O
Acetylene	0.117	117ppm
CO2	0.169	169ppm
CO	0.0028	28ppm
Ethane	0.0062	62ppm
Ethylene	0.0149	149ppm
Hydrogen	0.00016	1.6ppm
Methane	0.0023	23ppm
Nitrogen	0.0019	19ppm
Oxygen	0.0043	43ppm

For example if the calibration gas is 1% CO2 then the water would equilibrate to 169ppm times 1% equals 1.69ppm.

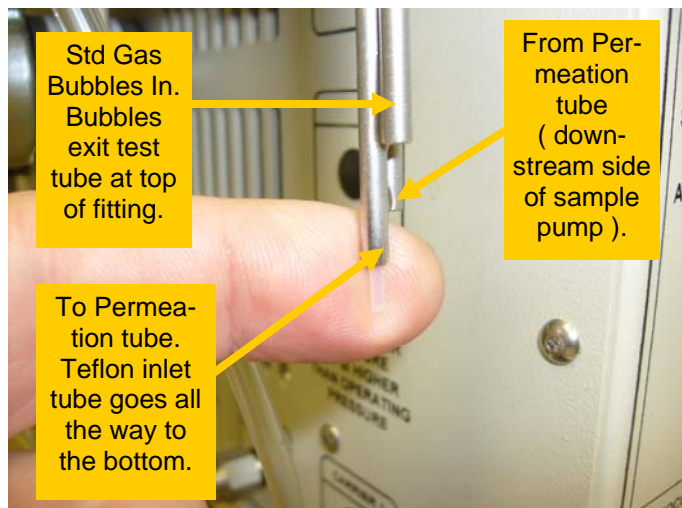
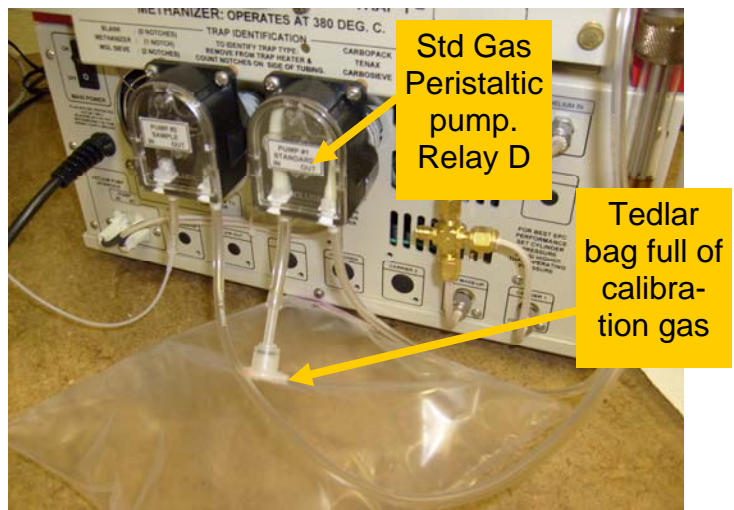
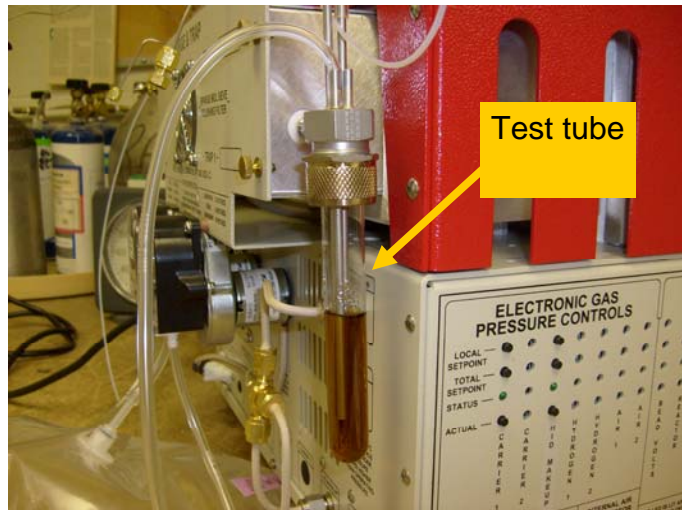

# Quick Field Test Procedure for the SRI Model 8610C TOGA configuration

To test the TOGA GC configuration:  
 1) Set the column temperature as shown below.

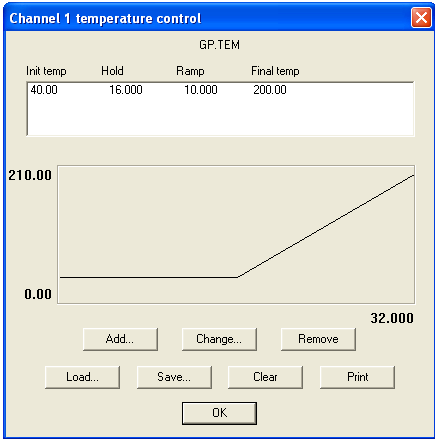

2) Enter the events as shown. You may have to modify the valve rotation times slightly depending on the elution times of the particular column set in the GC.

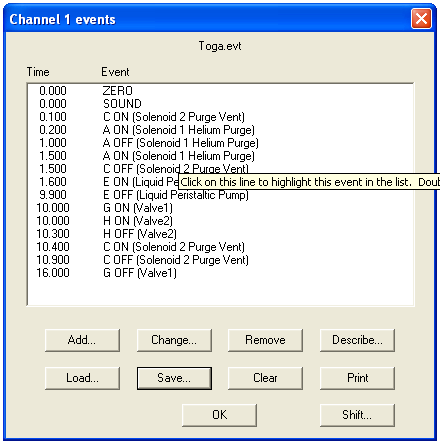

3) Plumb the tubing as shown in the photo.

1/16" Teflon exit Tubing to sample pump inlet

